

NO.	DATE	REVISIONS
C	CRR 18JAN17	REVISIONS PER ADDENDUM #1
B	CRR 6JAN17	ISSUED FOR PUBLIC BID
A	CRR 15DEC16	ISSUED FOR REVIEW NOT FOR CONSTRUCTION

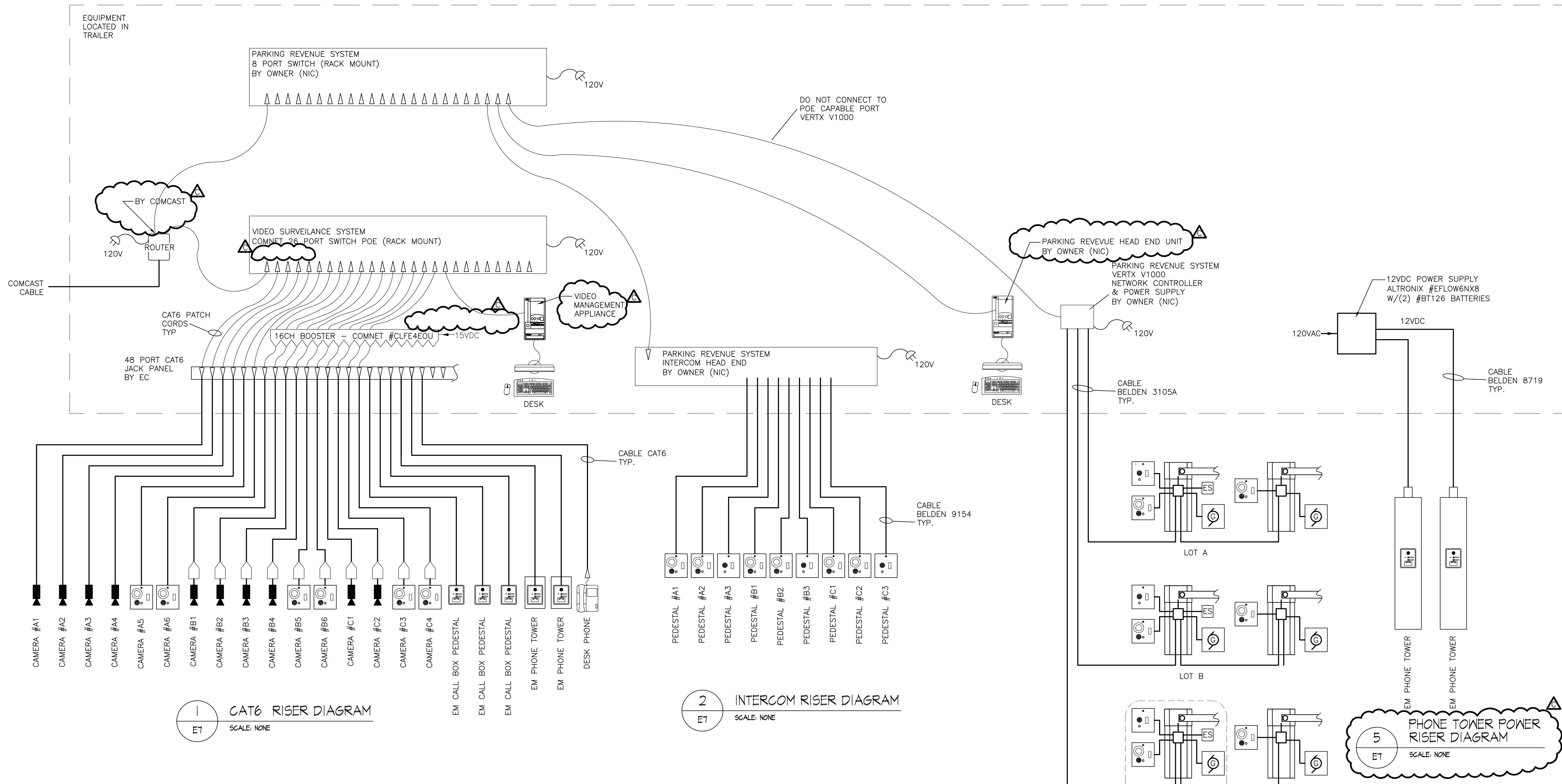

LEGEND

